

Numerical Generation of Boundary-Fitted Curvilinear Coordinate Systems for Arbitrarily Curved Surfaces

TOSHIYUKI TAKAGI AND KAZUYOSHI MIKI

*Energy Research Laboratory, Hitachi, Ltd.,
1168 Moriyama-cho, Hitachi-shi, Ibaraki-ken, 316 Japan*

AND

BRIAN C. J. CHEN AND WILLIAM T. SHA

*Argonne National Laboratory,
9700 South Cass Avenue, Argonne, Illinois 60439*

Received November 15, 1983

A new method is presented for numerically generating boundary-fitted coordinate systems for arbitrarily curved surfaces. The three-dimensional surface has been expressed by functions of two parameters using the geometrical modelling techniques in computer graphics. This leads to new quasi-one- and two-dimensional elliptic partial differential equations for coordinate transformation. Since the equations involve the derivatives of the surface expressions, the grids generated by the equations distribute on the surface depending on its slope and curvature. A computer program GRID-CS based on the method was developed and applied to a surface of the second order, a torus and a surface of a primary containment vessel for a nuclear reactor. These applications confirm that GRID-CS is a convenient and efficient tool for grid generation on arbitrarily curved surfaces. © 1985 Academic Press, Inc.

I. INTRODUCTION

Boundary-fitted curvilinear coordinate systems have been commonly used in the solution of partial differential equations for regions with arbitrarily shaped boundaries. A general method for generating the three-dimensional coordinate systems has been developed by Mastin and Thompson [1]. The method is based on the numerical solution of three-dimensional elliptic partial differential equations with Dirichlet boundary conditions. It is, however, difficult to specify the coordinates of grid points on the boundary surfaces for geometrically complicated surface.

Thomas [2] has proposed a method of automatically generating grids on a surface specified by the equation $z = F(x, y)$. A quasi-two-dimensional elliptic system has been then derived which takes the curvature of the surface into account. The method has been then applied to grid generation of an aircraft wing-body combination. However, use of the equation $z = F(x, y)$ for a surface representation limits its flexibility for adaption to a broad variety of curved surfaces.

In the present paper, the method of Thomas is extended to grid generation of an arbitrarily curved surface. Introducing geometric modelling techniques developed in the area of computer graphics, a curved surface is represented by the equations $x = f(s, t)$, $y = g(s, t)$, and $z = h(s, t)$ using two parameters s and t . A new quasi-two-dimensional elliptic system is derived for such surface representation, and also a quasi-one-dimensional elliptic system has been derived for curved lines of the surface edges. These two systems take the slope and curvature of the surface or curved line into account. On the basis of these elliptic systems, a new computer program, called GRID-CS, is developed. Its capabilities and applications are also presented here.

II. MATHEMATICAL FORMULATION

A. Quasi-Two-Dimensional Elliptic System

Three-dimensional boundary conforming grid coordinates are calculated by solving the following elliptic system of quasilinear equations [1, 2],

$$\alpha_1(r_{\xi\xi} + Pr_{\xi}) + \alpha_2(r_{\eta\eta} + Qr_{\eta}) + \alpha_3(r_{\zeta\zeta} + Rr_{\zeta}) + 2(\beta_1r_{\xi\eta} + \beta_2r_{\eta\xi} + \beta_3r_{\zeta\xi}) = 0, \quad (1)$$

where

$$r = (x, y, z), \quad (2)$$

$$\alpha_1 = (|r_{\eta}| |r_{\zeta}|)^2 - (r_{\eta} \cdot r_{\zeta})^2, \quad (3a)$$

$$\alpha_2 = (|r_{\zeta}| |r_{\xi}|)^2 - (r_{\zeta} \cdot r_{\xi})^2, \quad (3b)$$

$$\alpha_3 = (|r_{\xi}| |r_{\eta}|)^2 - (r_{\xi} \cdot r_{\eta})^2, \quad (3c)$$

$$\beta_1 = (r_{\eta} \cdot r_{\zeta})(r_{\zeta} \cdot r_{\xi}) - (r_{\xi} \cdot r_{\eta}) |r_{\zeta}|^2, \quad (3d)$$

$$\beta_2 = (r_{\zeta} \cdot r_{\xi})(r_{\xi} \cdot r_{\eta}) - (r_{\eta} \cdot r_{\zeta}) |r_{\xi}|^2, \quad (3e)$$

$$\beta_3 = (r_{\xi} \cdot r_{\eta})(r_{\eta} \cdot r_{\zeta}) - (r_{\zeta} \cdot r_{\xi}) |r_{\eta}|^2. \quad (3f)$$

Here, (x, y, z) and (ξ, η, ζ) are coordinates in physical and transformed spaces; the subscripts ξ and $\xi\xi$ indicate the first- and second-order partial derivatives with respect to ξ , and P , Q , and R are functions to control grid spacings.

Thomas [2] derived from the above system a quasi-two-dimensional elliptic system using the following assumptions:

- (1) The surface is represented as a coordinate surface $\zeta = \text{const}$ (see Fig. 1).
- (2) The ζ -directed transverse coordinate lines are orthogonal to the surface $\zeta = \text{const}$.
- (3) The principal curvatures of the ζ -directed coordinate lines vanish locally at the surface.

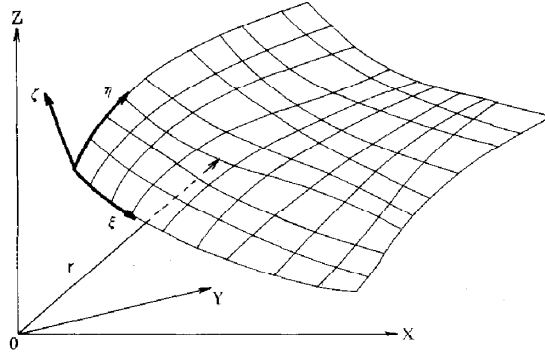

FIG. 1. Curvilinear coordinates on a curved surface.

Orthogonality is written as

$$r_{\xi} \cdot r_{\zeta} = r_{\eta} \cdot r_{\zeta} = 0 \tag{4}$$

and the third assumption is expressed by

$$r_{\zeta\zeta} = (|r_{\zeta}|_{\zeta} / |r_{\zeta}|) r_{\zeta}. \tag{5}$$

Substituting Eqs. (4) and (5) into Eq. (1) and eliminating the variable R in the first two scalar components of Eq. (1) using the third one, the following two scalar equations are obtained,

$$\begin{aligned} &|r_{\eta}|^2 \{ (x_{\xi\xi} + Px_{\xi}) + v(z_{\xi\xi} + Pz_{\xi}) \} + |r_{\xi}|^2 \{ (x_{\eta\eta} + Qx_{\eta}) + v(z_{\eta\eta} + Qz_{\eta}) \} \\ &\quad - 2(r_{\xi} \cdot r_{\eta})(x_{\xi\eta} + v z_{\xi\eta}) = 0, \end{aligned} \tag{6a}$$

$$\begin{aligned} &|r_{\eta}|^2 \{ (y_{\xi\xi} + Py_{\xi}) + w(z_{\xi\xi} + Pz_{\xi}) \} + |r_{\xi}|^2 \{ (y_{\eta\eta} + Qy_{\eta}) + w(z_{\eta\eta} + Qz_{\eta}) \} \\ &\quad - 2(r_{\xi} \cdot r_{\eta})(y_{\xi\eta} + w z_{\xi\eta}) = 0, \end{aligned} \tag{6b}$$

where

$$\begin{aligned} v &= -\frac{x_{\zeta}}{z_{\zeta}} = \frac{y_{\eta}z_{\xi} - y_{\xi}z_{\eta}}{x_{\xi}y_{\eta} - x_{\eta}y_{\xi}}, \\ w &= -\frac{y_{\zeta}}{z_{\zeta}} = \frac{x_{\xi}z_{\eta} - x_{\eta}z_{\xi}}{x_{\xi}y_{\eta} - x_{\eta}y_{\xi}}. \end{aligned}$$

Thomas derived the final elliptic system by eliminating z in Eqs. (6) using the function $z = F(x, y)$ which specifies a surface.

In the present method, all Cartesian coordinates $x, y,$ and z in Eqs. (6) are

eliminated using the following function that defines the surface, (hereafter called surface functions),

$$x = f(s, t), \quad (7a)$$

$$y = g(s, t), \quad (7b)$$

$$z = h(s, t). \quad (7c)$$

The first- and second-order derivatives of x are obtained, by partially differentiating Eq. (7a) with respect to ξ and/or η ,

$$x_\xi = f_s s_\xi + f_t t_\xi, \quad (8a)$$

$$x_\eta = f_s s_\eta + f_t t_\eta, \quad (8b)$$

$$x_{\xi\xi} = f_{ss} s_\xi^2 + 2f_{st} s_\xi t_\xi + f_{tt} t_\xi^2 + f_s s_{\xi\xi} + f_t t_{\xi\xi}, \quad (8c)$$

$$x_{\eta\eta} = f_{ss} s_\eta^2 + 2f_{st} s_\eta t_\eta + f_{tt} t_\eta^2 + f_s s_{\eta\eta} + f_t t_{\eta\eta}, \quad (8d)$$

$$x_{\xi\eta} = f_{ss} s_\xi s_\eta + f_{st} (s_\xi t_\eta + s_\eta t_\xi) + f_{tt} t_\xi t_\eta + f_s s_{\xi\eta} + f_t t_{\xi\eta}. \quad (8e)$$

Substituting Eqs. (8), and similar derivatives of y and z into Eqs. (6) and manipulating the resultant equations algebraically, a new quasi-two-dimensional elliptic system can be obtained,

$$|r_\eta|^2 (s_{\xi\xi} + P s_\xi) + |r_\xi|^2 (s_{\eta\eta} + Q s_\eta) - 2(r_\xi \cdot r_\eta) s_{\xi\eta} + J^2 \Phi = 0, \quad (9a)$$

$$|r_\eta|^2 (t_{\xi\xi} + P t_\xi) + |r_\xi|^2 (t_{\eta\eta} + Q t_\eta) - 2(r_\xi \cdot r_\eta) t_{\xi\eta} + J^2 \Psi = 0, \quad (9b)$$

where J denotes the two-dimensional Jacobian determinant,

$$J = s_\xi t_\eta - s_\eta t_\xi$$

and the nonlinear coefficients are scalars that can be evaluated from the surface functions $f(s, t)$, $g(s, t)$, and $h(s, t)$ as follows:

$$|r_\eta|^2 = D s_\eta^2 + E t_\eta^2 - F s_\eta t_\eta,$$

$$|r_\xi|^2 = D s_\xi^2 + E t_\xi^2 - F s_\xi t_\xi,$$

$$(r_\xi \cdot r_\eta) = D s_\xi s_\eta + E t_\xi t_\eta - \frac{F}{2} (s_\xi t_\eta + s_\eta t_\xi),$$

$$\Phi = (A_1 D + A_2 E + A_3 F) / (A^2 + B^2 + C^2),$$

$$\Psi = (A_4 D + A_5 E + A_6 F) / (A^2 + B^2 + C^2),$$

$$A_1 = B_1 f_{tt} + B_2 g_{tt} + B_3 h_{tt},$$

$$A_2 = B_1 f_{ss} + B_2 g_{ss} + B_3 h_{ss},$$

$$A_3 = B_1 f_{st} + B_2 g_{st} + B_3 h_{st},$$

$$A_4 = B_4 f_{tt} + B_5 g_{tt} + B_6 h_{tt},$$

$$A_5 = B_4 f_{ss} + B_5 g_{ss} + B_6 h_{ss},$$

$$A_6 = B_4 f_{st} + B_5 g_{st} + B_6 h_{st},$$

$$B_1 = Ag_t + Ch_t,$$

$$B_2 = -(Af_t + Bh_t),$$

$$B_3 = Bg_t - Cf_t,$$

$$B_4 = -(Ag_s - Ch_s),$$

$$B_5 = Af_s + Bh_s,$$

$$B_6 = Cf_s - Bg_s,$$

$$A = f_s g_t - f_t g_s,$$

$$B = g_t h_s - g_s h_t,$$

$$C = f_s h_t - f_t h_s,$$

$$D = f_s^2 + g_s^2 + h_s^2,$$

$$E = f_t^2 + g_t^2 + h_t^2,$$

$$F = -2(f_s f_t + g_s g_t + h_s h_t).$$

The functions P and Q in Eqs. (9) may be chosen to make the grid to concentrate as desired. The following are obtained by modifying the forms incorporated in the TOMCAT program of Thompson *et al.* [3],

$$P(\xi, \eta) = - \sum_{i=1}^m a_{i1} \operatorname{sgn}(\xi - \xi_i) \exp[-b_{i1} \{c_{i11}(\xi - \xi_i)^2 + c_{i21}(\eta - \eta_i)^2\}^{1/2}], \quad (10a)$$

$$Q(\xi, \eta) = - \sum_{i=1}^n a_{i2} \operatorname{sgn}(\eta - \eta_i) \exp[-b_{i2} \{c_{i12}(\xi - \xi_i)^2 + c_{i22}(\eta - \eta_i)^2\}^{1/2}]. \quad (10b)$$

As shown in Fig. 2, Eqs. (9) give the relationship between the two planes: the $\xi - \eta$ computational plane and the $s - t$ parameter plane, and Cartesian coordinates in a physical space can be evaluated by Eqs. (7). Eqs. (9) can thus generate a quasi-two-dimensional coordinates system on the $s - t$ parameter plane. The curvature of the surface is taken into account through the terms involving the functions Φ and Ψ . In the case of a plane surface, where the surface functions can be given by

$$x = f(s, t) = s,$$

$$y = g(s, t) = t,$$

$$z = h(s, t) = 0.$$

The functions Φ and Ψ become zero and Eqs. (9) reduce to the two-dimensional

plane equation [3]. Equations (9) also become identical to the elliptic system deduced by Thomas in the following case,

$$\begin{aligned}x &= f(s, t) = s, \\y &= g(s, t) = t, \\z &= h(s, t) = F(s, t).\end{aligned}$$

B. *Quasi-One-Dimensional Elliptic System*

Quasi-two-dimensional grid coordinates on a curved surface can be calculated by solving Eqs. (9) with grid coordinates specified on the curved edges of the surface as Dirichlet boundary values. To automatically generate grids on the curves, a quasi-one-dimensional elliptic system is derived under the following assumptions:

(1) The curve is represented as a ξ -directed coordinate line defined by $\eta = \text{const.}$ and $\zeta = \text{const.}$

(2) The η - and ζ -directed transverse coordinate lines are orthogonal to the line specified by assumption (1).

(3) The principal curvatures of the η - and ζ -directed transverse coordinate lines vanish locally at the ξ -directed line.

These assumptions give the following relations in addition to Eqs. (4) and (5),

$$r_{\eta\eta} = (|r_{\eta}|_{\eta}/|r_{\eta}|) r_{\eta}, \quad (11a)$$

$$r_{\xi} \cdot r_{\eta} = 0. \quad (11b)$$

Substituting Eqs. (4), (5), and (11) into Eq. (1) and eliminating the variables R and Q in the first scalar component of Eq. (1), the following scalar equation is obtained,

$$x_{\xi}(x_{\xi\xi} + Px_{\xi}) + y_{\xi}(y_{\xi\xi} + Py_{\xi}) + z_{\xi}(z_{\xi\xi} + Pz_{\xi}) = 0. \quad (12)$$

The curved line can be represented by Eqs. (7)

$$x = f(o, t) = i(t), \quad (13a)$$

$$y = g(o, t) = j(t), \quad (13b)$$

$$z = h(o, t) = k(t), \quad (13c)$$

where the curve is assumed to be edge ③ of the curved surface as shown in Fig. 2. The other three edges can be represented in the same way. The first- and second-order derivatives of x are given using Eqs. (13) as

$$x_{\xi} = i_t t_{\xi}, \quad (14a)$$

$$x_{\xi\xi} = i_{tt} t_{\xi}^2 + i_t t_{\xi\xi}. \quad (14b)$$

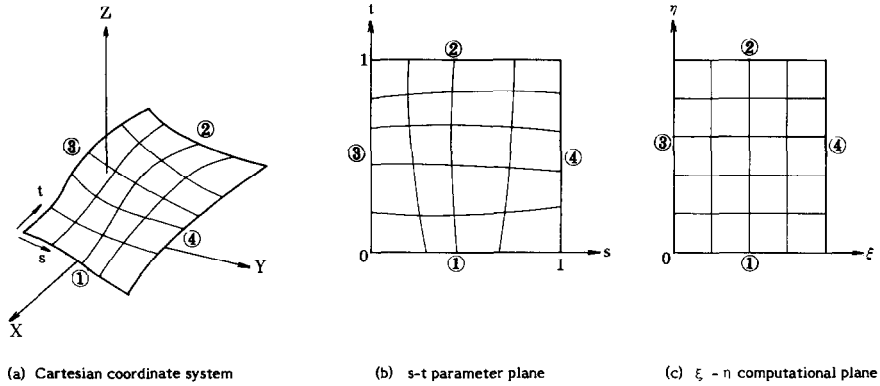

FIG. 2. Transformation from Cartesian coordinate system to $\xi - \eta$ computational plane.

Substitution of Eqs. (14) and similar derivatives of y and z into Eq. (12) then yields a quasi-one-dimensional elliptic system.

$$t_{\xi\xi} + Pt_{\xi} + \frac{i_t i_{tt} + j_t j_{tt} + k_t k_{tt}}{i_t^2 + j_t^2 + k_t^2} t_{\xi}^2 = 0. \quad (15)$$

The curvature is taken into account through the last term involving derivatives of the functions $i, j,$ and k . In the case of a straight line represented by

$$\begin{aligned} x &= i(t) = t, \\ y &= j(t) = 0, \\ z &= k(t) = 0, \end{aligned}$$

Eq. (15) reduces to a one-dimensional elliptic system.

III. COMPUTER PROGRAM AND APPLICATIONS

A. Description of GRID-CS Program

A new computer program GRID-CS has been developed on the basis of Eqs. (9) and (15). Figure 3 illustrates its calculational flow. Grids on a curved surface are generated by the following four steps:

Step 1. A curved surface is specified by the surface functions, Eqs. (7), which can not only be given as mathematical functions in advance but can also be automatically generated by providing a small number of grid points on the surface. Geometric modelling techniques are used to fit the input grid points smoothly as described in the next section.

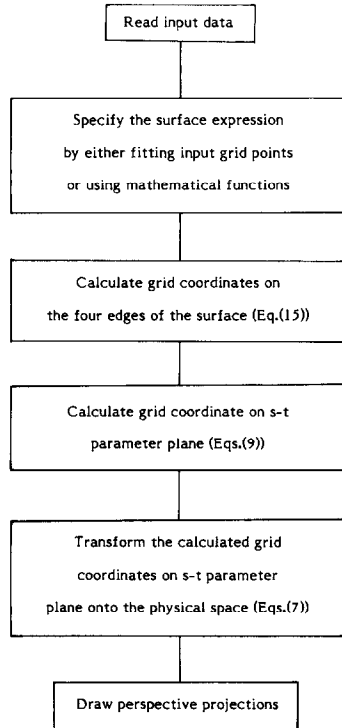

FIG. 3. Calculation steps in GRID-CS.

Step 2. Grids on the four curved edges of the surface are generated by solving the quasi-one-dimensional elliptic system, Eq. (15).

Step 3. Grids on the $s-t$ parameter plane are generated by solving the quasi-two-dimensional elliptic system, Eqs. (9), with the boundary grids obtained in Step 2 as Dirichlet boundary conditions.

Step 4. The grids on the $s-t$ parameter plane are transformed to the physical (x, y, z) space using Eqs. (7).

B. Curved Surface Fitting by Geometric Modelling Technique

The program GRDI-CS is capable of generating the surface expression, Eqs. (7). The entire surface is obtained by the summation of bilinearly blended Coons patches. As shown in Fig. 4, every patch is composed of four input points as corner points. The four edges of a patch can be expressed by modified Bezier curves [4] in advance of the patch calculation.

In the modified Bezier curve representation, the equation, U_{ij} of the line segment

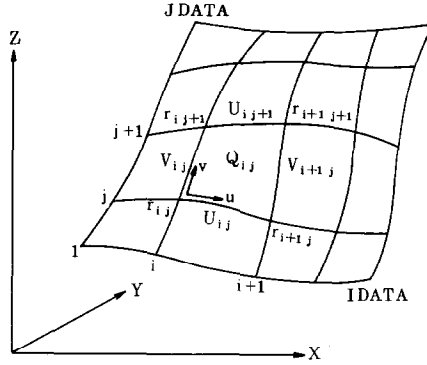

FIG. 4. Curved surface as a summation of bilinearly Coons patches composed of four input points and variables related to the function Q_{ij} .

between input grid points r_{ij} and r_{i+1j} shown in Figs. 4 and 5, is written in vector forms,

$$U_{ij} = (1-u)^3 r_{ij} + 3u(1-u^2) r_{ij1} + 3u^2(1-u) r_{ij2} + u^3 r_{i+1j}, \quad 0 \leq u \leq 1, \quad (16)$$

where the u coordinate is defined in a line segment, and r_{ij1} and r_{ij2} are coordinate vectors of unknown points which control the shape of a line segment. A line segment, U_{ij} must be connected to the neighboring segments, U_{i-1j} and U_{i+1j} smoothly with the same slope and curvature at the boundaries, r_{ij} and r_{i+1j} . Hence the following vector equation must be satisfied [4],

$$B_{ij} + 2k_{ij}(1+k_{ij}) B_{i+1j} + k_{ij}^2 k_{i+1j} B_{i+2j} = A_{ij} + k_{ij}^2 A_{i+1j}, \quad (17a)$$

$$C_{ij} = k_{ij} B_{i+1j}, \quad (17b)$$

where

$$A_{ij} = r_{i+1j} - r_{ij},$$

$$B_{ij} = r_{ij1} - r_{ij},$$

$$C_{ij} = r_{i+1j} - r_{ij2},$$

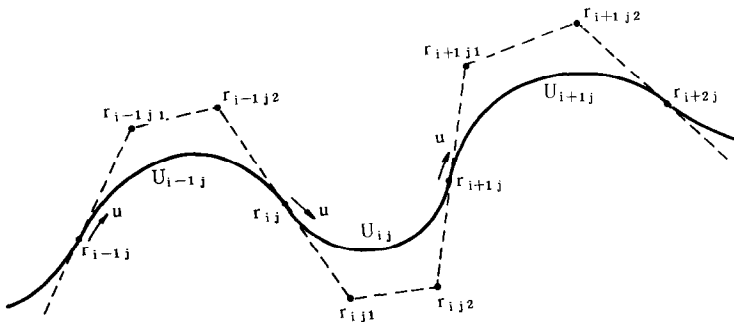

FIG. 5. Modified Bezier curves (—) and controlling lines (---).

and a constant k_{ij} can be decided on, depending on the absolute value of A_{ij} [4]. By solving Eqs. (17) with one of the fixed, natural, and periodic boundary conditions, the unknown coordinate vectors r_{ij1} and r_{ij2} are obtained, and U_{ij} is calculated by Eq. (16).

The bilinearly blended Coons patch can be expressed using not only four corner points but also four edge lines, which leads more precise surface representation than the simple bilinear patch using only the corner points. The bilinearly blended Coons patch composed of coordinate vectors, r_{ij} , r_{i+1j} , r_{ij+1} , and r_{i+1j+1} is expressed by,

$$Q_{ij}(u, v) = [1 - u \ u] \begin{bmatrix} V_{ij}(v) \\ V_{i+1j}(v) \end{bmatrix} + [U_{ij}(u) \ U_{ij+1}(u)] \begin{bmatrix} 1 - v \\ v \end{bmatrix} - [1 - u \ u] \begin{bmatrix} r_{ij} & r_{ij+1} \\ r_{i+1j} & r_{i+1j+1} \end{bmatrix} \begin{bmatrix} 1 - v \\ v \end{bmatrix}, \quad (18)$$

where u and v are coordinates defined on a surface patch shown in Fig. 4 and have the values between zero and one, and U_{ij} , V_{ij} , etc., are the equations of line segments given by the modified Bezier curves. The three scalar components of Eq. (18) give the surface expression, Eqs. (7) in each patch with the help of the following relations between (s, t) and (u, v) ,

$$s = \frac{u + i - 1}{IDATA - 1}, \quad t = \frac{v + j - 1}{JDATA - 1},$$

where i and j define the region of a patch as shown in Fig. 4. IDATA and JDATA represent the number of input points in the i and j directions, respectively.

C. Numerical Results and Discussions

The program GRID-CS has been applied to grid generation for three kinds of curved surfaces. Figures 6–8 show calculated grids, and edge numbers defined in Fig. 2.

The first example is the surface of the second order given by the following functions:

$$\begin{aligned} x &= 8s, \\ y &= 12t, \\ z &= 14.4t(t - 1) - 19.2s(s - 1). \end{aligned}$$

The 961 calculated grids on the surface are shown in Figs. 6a and b for a perspective projection and a projection on $x - y$ plane, respectively. The latter has a non-uniform grid distribution because the program GRID-CS can take the slope and the curvature of a surface into account through Eqs. (9). The program can generate as many grids as one hopes by changing only the input data of the maximum numbers in the s and t directions.

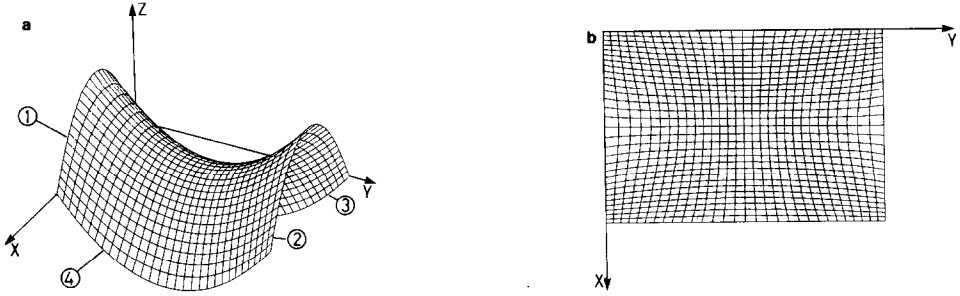

FIG. 6. (a) Perspective projection of a surface of the second order. (b) Projection on $x - y$ plane of a surface of the second order.

The second example demonstrates an application to the surface of a 120-degree segment of a torus. Figure 7a shows 961 generated grids from 64 input points by using the curved surface fitting technique described in Section III.B. The coordinates of the input grid points were given by the following function,

$$x = R - (R - r \cos \theta) \cos \varphi, \quad (19a)$$

$$y = (R - r \cos \theta) \sin \varphi, \quad (19b)$$

$$z = r \sin \theta, \quad (19c)$$

where R and r are major and minor radii of the torus, respectively. In this case R and r are 6 and 4, respectively. θ and φ are angles along poloidal and toroidal directions, respectively, as shown in Fig. 7c. The maximum deviation of the generated grid points from the original torus expressed by Eqs. (19) is less than 0.6% of the minor radius. Figure 7b shows the grid concentration in a particular region on the upper half of the 120-degree segment of the torus by using the controlling functions P and Q . The coefficients used in P and Q have the following values.

$$\begin{aligned} m &= 2, & n &= 2 \\ \xi_1 &= 1, & \xi_2 &= 31, & \eta_1 &= 1, & \eta_2 &= 31, \\ a_{11} &= a_{21} = a_{12} = a_{22} &= 0.5, \\ b_{11} &= b_{21} = b_{12} = b_{22} &= 0.1, \\ c_{111} &= c_{211} = c_{122} = c_{222} &= 1, & c_{121} &= c_{221} = c_{112} = c_{212} &= 0. \end{aligned}$$

The last example presents the grid generation on the surface of a primary containment vessel for a nuclear reactor. Figure 8a shows 400 generated grids on half of the vessel from 60 input points obtained from a vessel plan. Figure 8b shows the finer grid structure on the upper one-third of the vessel, in which 896 grids are generated from 48 input points.

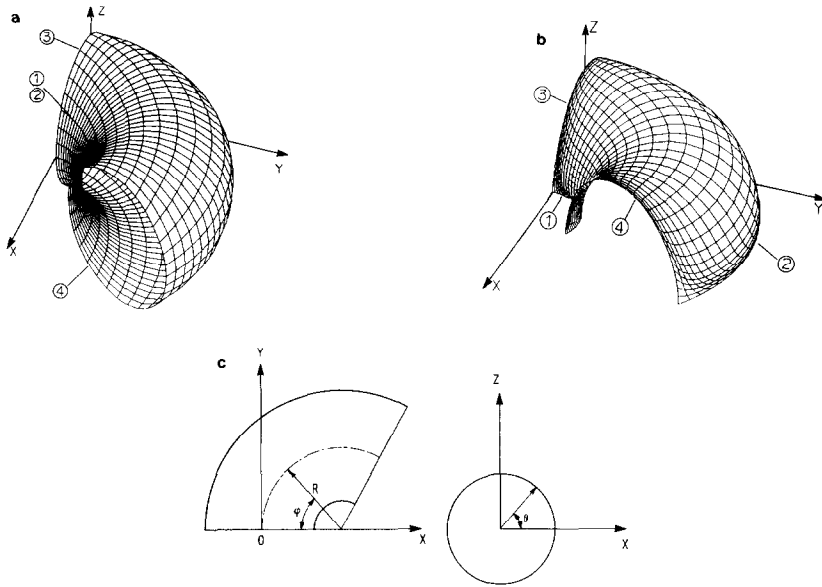

FIG. 7. (a) Perspective projection of a 120-degree segment of a torus. (b) Perspective projection of the upper half of a 120-degree segment of a torus with concentrated grids. (c) Definition of variables used for a torus.

The finite element method has geometrical advantages for matching complicated boundaries, but it requires much experience and time for constructing appropriate grid points. The three-dimensional boundary element method analyzes the physical quantity of interest on the domain surface. It has the same problems inherent in constructing grids. The grid points on the curved surface can be obtained by setting the small divisions of s and t in Eqs. (7). But the grids automatically generated by

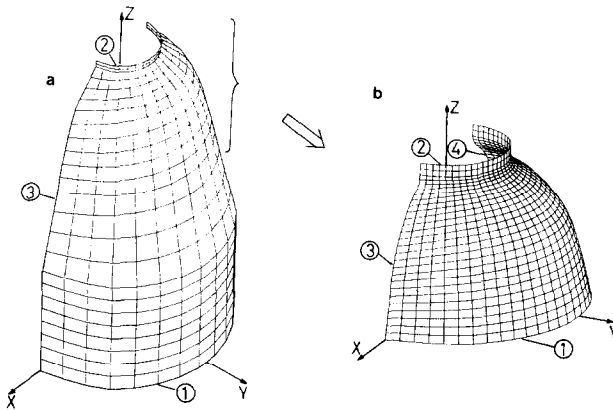

FIG. 8. (a) Perspective projection of a half of a primary containment vessel for a nuclear reactor. (b) Perspective projection of the upper one-third of a primary containment vessel for a nuclear reactor.

the present method would be more appropriate to the analysis by the boundary element and finite element method. Because the method takes the surface slope and curvature into account.

IV. CONCLUSION

A new method has been presented for numerically generating boundary-fitted curvilinear coordinate systems for arbitrarily curved surfaces. The method uses the geometrical modelling techniques of modified Bezier curves and bilinearly blended Coons patches for expressing a curved surface using the parameter. The surface expressions can be specified by giving the small number of representative points. On the basis of such surface expressions, new quasi-one- and two-dimensional elliptic partial differential equations were derived for coordinate transformation. Since the equations involve the derivatives of the surface expressions, the grids generated by the equations distribute on the surface depending on its slope and curvature.

A computer program GRID-CS was developed by means of the method, and was applied to (a) a surface of the second order, (b) a torus, and (c) a surface of a primary containment vessel for nuclear reactor. These applications confirmed that GRID-CS is a convenient and efficient tool for generation of quasi-two-dimensional grids on arbitrarily curved surfaces.

Grids numerically generated by GRID-CS, can be used as Dirichlet boundary conditions for the computer program GRID-3D [6], which can generate three-dimensional grids within a complicated geometry consisting of many different components. The grids from GRID-CS could also be used as nodal points in the finite element and the boundary element methods. Therefore GRID-CS could significantly improve productivity of computer-aided-design (CAD).

ACKNOWLEDGMENTS

The authors would like to acknowledge Dr. R. Takeda of Energy Research Laboratory, Hitachi Ltd. for his valuable discussions. Acknowledgment is also due of Drs. K. Taniguchi, S. Yamada, and M. Serizawa of the same Laboratory, Hitachi Ltd. for their sustained encouragement.

REFERENCES

1. C. W. MASTIN AND J. F. THOMPSON, *Numer. Math.* **29** (1978), 397.
2. P. D. THOMAS, Construction of composite three-dimensional grids from subregion grids generated by elliptic systems, in "AIAA Comput. Fluid. Dynam. Conf., Palo Alto," Paper No. 81-0996, p. 24, 1981.
3. J. F. THOMPSON, F. C. THAMES, AND C. W. MASTIN, *J. Comput. Phys.* **24** (1977), 274.
4. M. HOSAKA AND F. KIMURA, *J. Inform. Process. Soc. of Japan* **21** (1980), 481. [Japanese]
5. S. A. COONS, "Surfaces for Computer-Aided Design of Space Forms," MIT, MAC-TR-41, 1967.
6. K. MIKI, T. TAKAGI, B. C. J. CHEN AND W. T. SHA, *J. Comput. Phys.*, **53**, (1984), 319.